

PEREGRINE

2 Axis Non-contact Measuring System



Assembly, Usage & Maintenance Guidelines



Peregrine 2-axis Non-Contact Measurement

Peregrine is a 2-axis video measuring system with optical and video measurement capability.

Vision's patented optical viewing system presents the operator with a magnified crisp, bright and undistorted view of the component to be measured. Below the Peregrine's optics the accurate XY stage is moved, allowing for features to be positioned on the central crosshair, shown in the viewing head.

A QC-300 Microprocessor is connected to the Peregrine stage. Data points are entered into the Microprocessor through the integral keypad (for further details of QC-300 operation, see the QC-300 User Guide).

Peregrine is a modular system that can be combined with a range of accessories including alternative magnification, illumination, image capture and data processing options. For further details, contact your Vision Engineering representative or distributor.

To achieve the most from this precision instrument, please read the enclosed assembly instructions, usage and maintenance guidelines.

Contents

Packing Contents

Stage & Stand Pack	1
Head Pack	1
Microprocessor Pack	1
Focus Pack Optional Items	2
Accessories Packs	2
Footswitch	2

Assembly

Stage Assembly	3
Fibre-Optic Cable Connection	4
Ringlight Cable Connection	4
Focus Assembly Attachment	5
Attaching Head	5
EPI Attachment	6
Ringlight & Spotlight Attachment (with EPI)	6
Objective Lens	7
Attaching LED ringlight	7
Attaching Spot Illuminator	7
Photographic Attachments	8
Microprocessor Assembly	8
System Cable Connection	9

Operation & Setup

Main System Controls	10
Stage Glass Levelling	10
EPI/Lens Controls	10
Graticule Adjustment	11
Spot Adjustment	11

How to use your Peregrine Measuring System

Objective Lens	13
Illumination Options	13
Taking a Measurement	14
Good Working Practices	15

Getting the most from your Peregrine

Routine Maintenance (see pages 17, 18)	16
Consumable & Replacement Parts:	16
Environmental Considerations	16

Routine Maintenance

General Maintenance Points	17
Sub-Stage Lamp Changing	18
Illuminator Lamp Changing	18

Accessories & Options

Family Tree	19
-------------	----

Accessories & Additional Features

Ringlight	20
Episcopic Illumination	20
Camera Arm	20
Lens Options	20
Anti-glare Hood	20
Peregrine Foot Switch	20
Parts List	20

Other Solutions from Vision Engineering

Stereo Inspection Systems	21
Non-Contact Measuring Systems	22

Service & Calibration Record

Addresses

Please look for the following parts in each pack. Each pack has a check list on the outside of its contents.

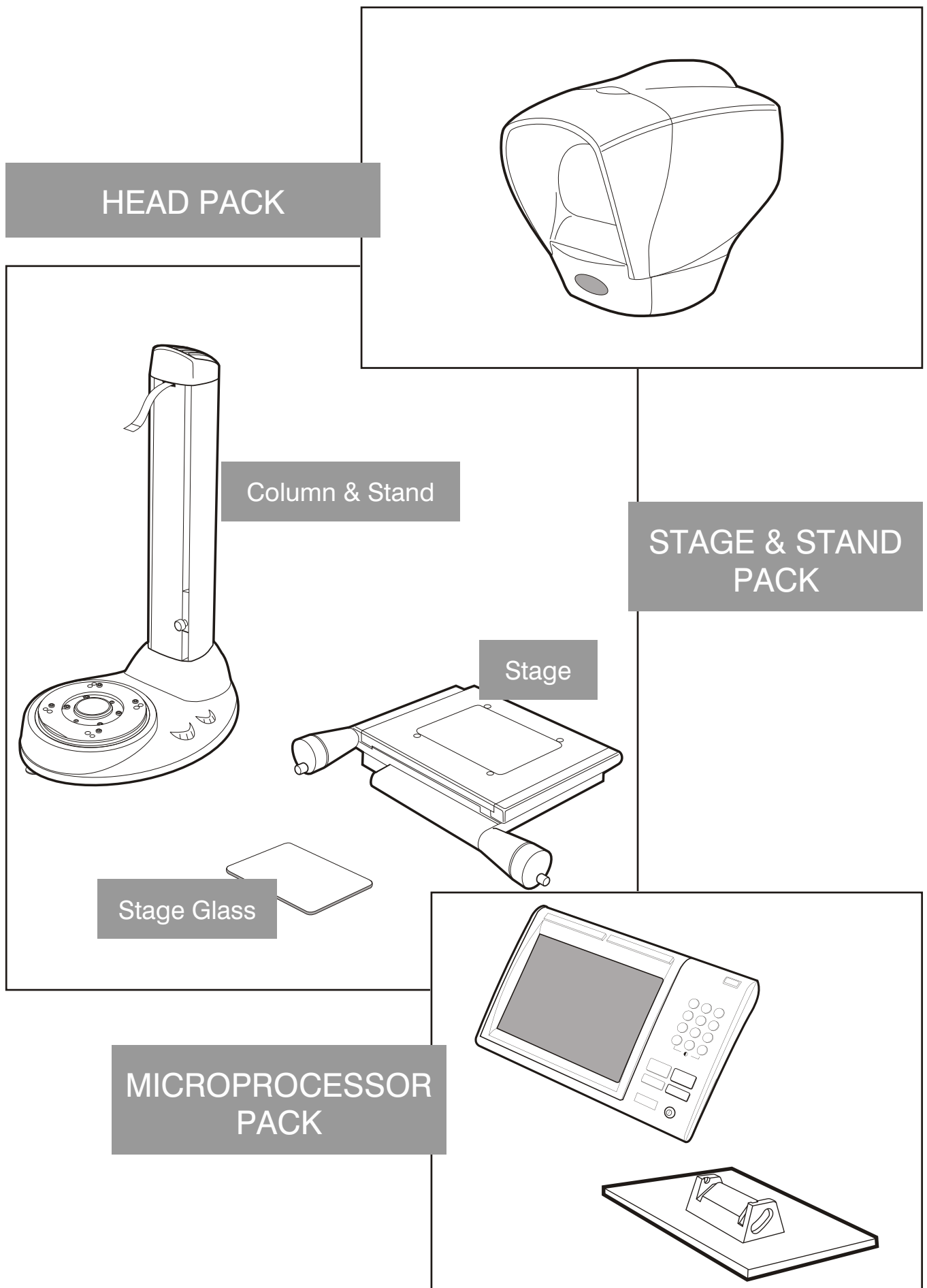

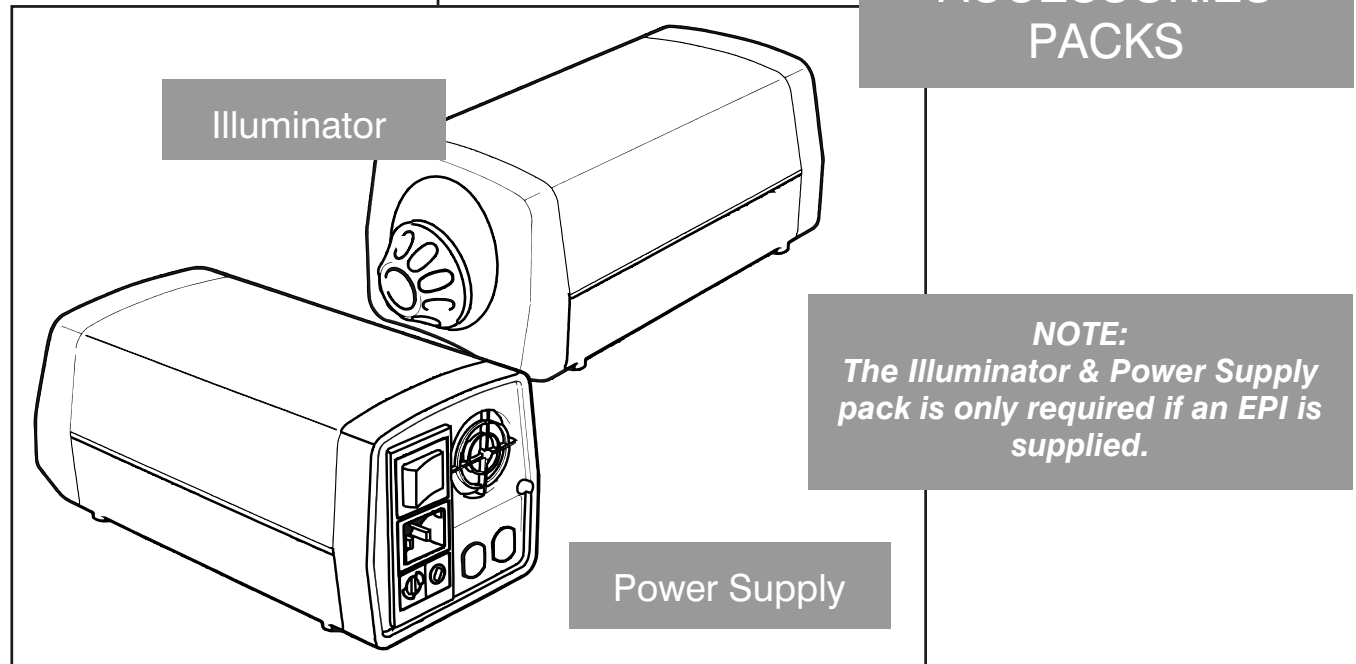
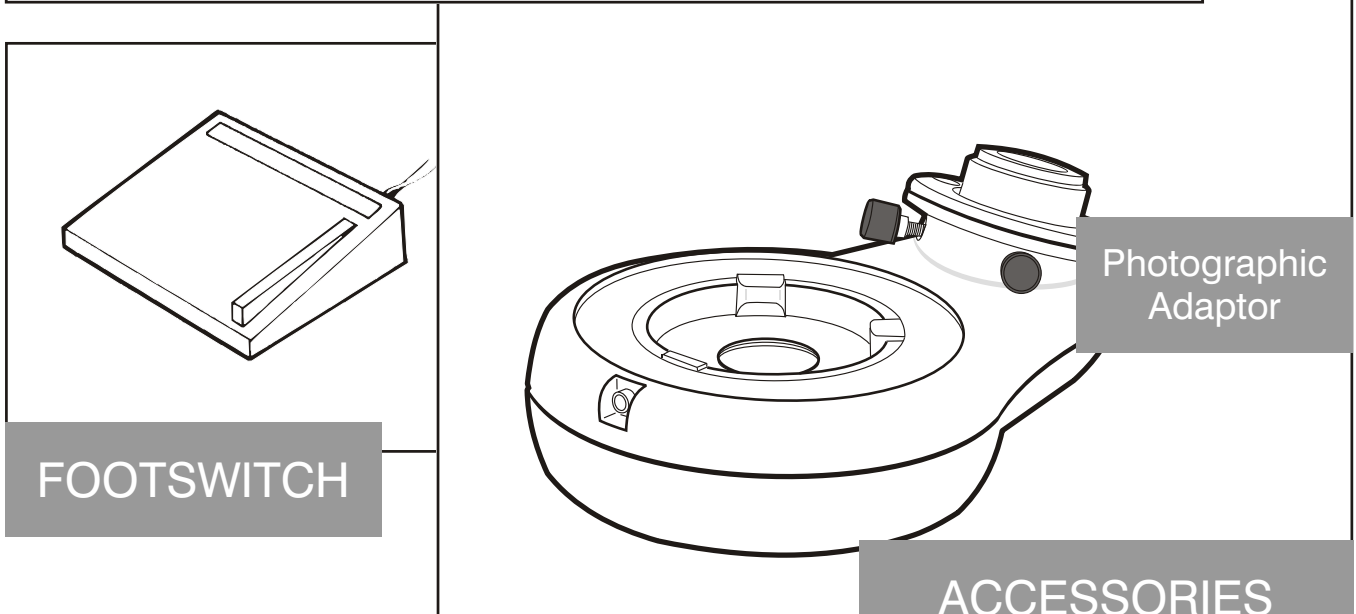
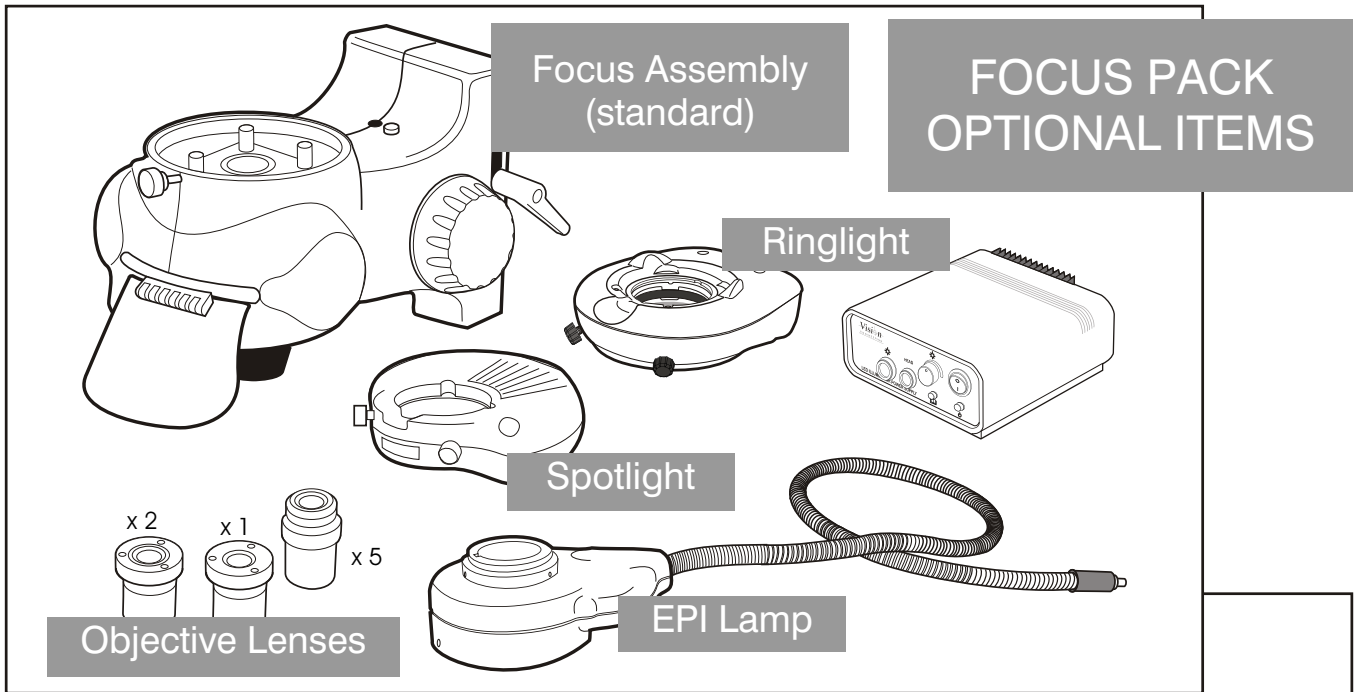

STAGE ASSEMBLY

Remove the red locking plate at the rear of the stage.

Check the adjustable pad on the stage is retracted up into the stage bottom plate. The adjustable pad is controlled by the screw in the rear left hole in the aperture under the stage glass.

Check the stand base plate and the underside of the stage are clean and free of any debris.

Place the stage on the stand base plate and align the three bolt holes. Screw in the Allen bolts until they just touch down. When all three bolts are in, tighten them to a torque setting of 2Nm (equal to 'touch down' plus $\frac{1}{8}$ turn).

NOTE:

The bolts must be tightened in the sequence: front right, front left then back right.

Once the 3 Allen bolts are in place, set the adjustable pad using a flat headed screwdriver. Adjust the screw until it just touches down - DO NOT USE FORCE! If this screw is over tightened, the base plate will distort.

Remove the second red locking plate from the left-hand side of the stage and fit the glass into its recess.

NOTE:
Ensure the Stage Glass is in contact with all 4 supports.

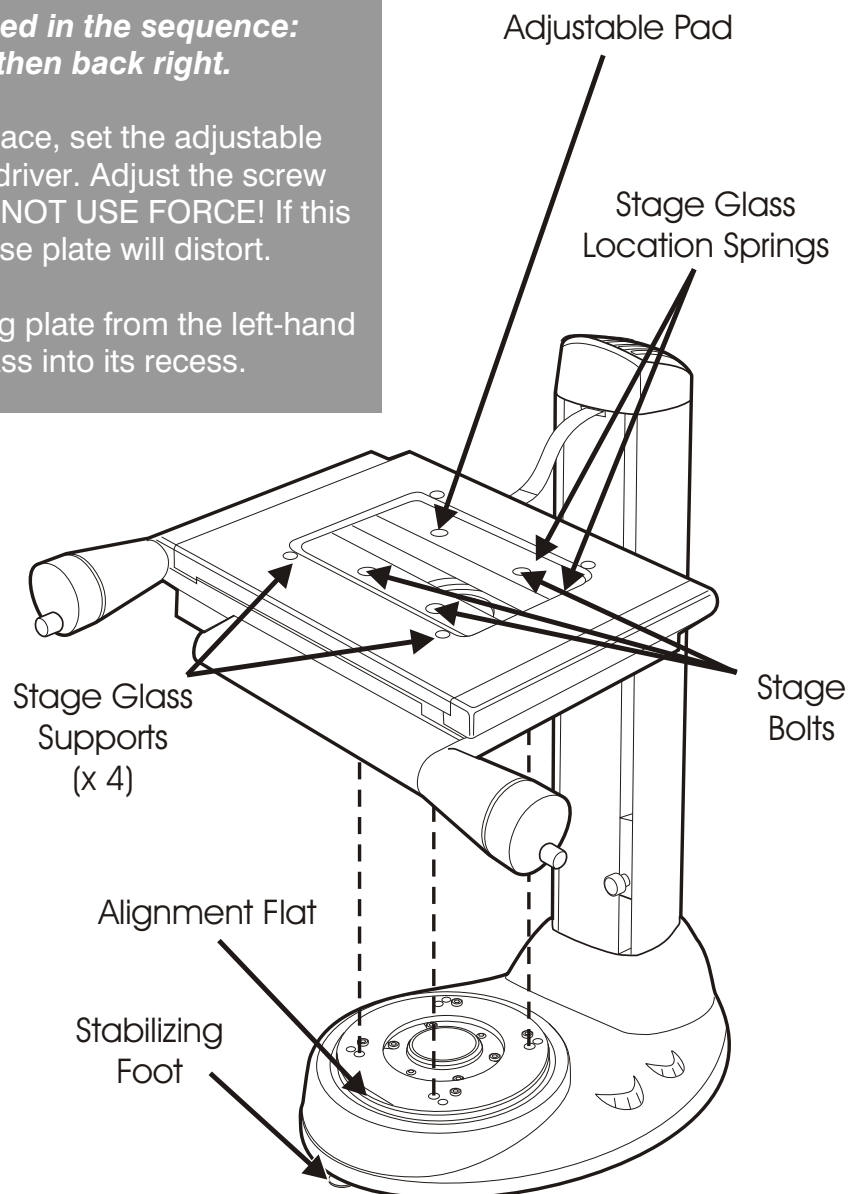

FIBRE-OPTIC CABLE CONNECTION

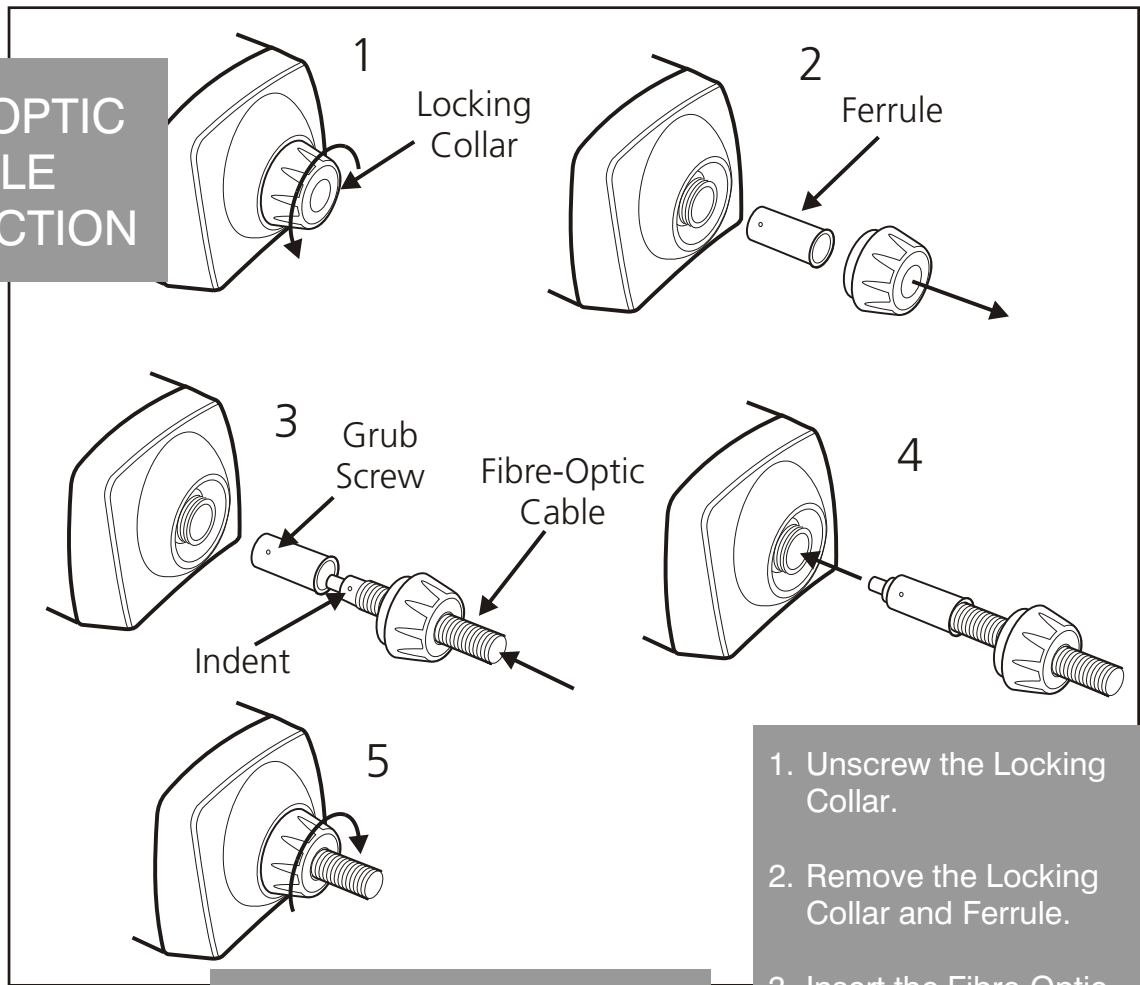

NOTE:
Only for EPI option

1. Unscrew the Locking Collar.

2. Remove the Locking Collar and Ferrule.

3. Insert the Fibre-Optic cable through the Collar and Ferrule. Align the Grub Screw with the indent on the cable and tighten the screw with the Allen key provided (taped to the base of the illuminator).

4. Insert the cable and Ferrule into the illuminator.

5. Tighten the Collar.

RINGLIGHT CABLE CONNECTION

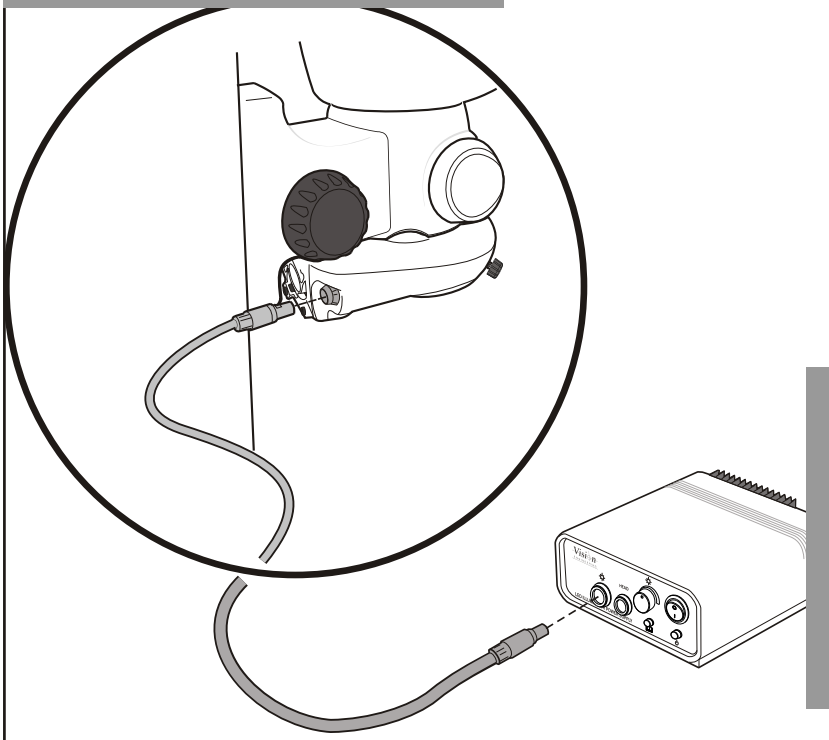

Connect the LED ringlight cable to the illuminator socket on the front of the control box.

Connect the other end of the cable to the connector on the rear of the LED ringlight.

FOCUS ASSEMBLY ATTACHMENT

Ensure the Coarse Travel Stop is at its lowest position and the Anti-Glare Shield is raised.

Remove the Column Cap. Slide the assembly on to the column just enough to allow the column connector to be attached to the male connector at the rear of the assembly. Replace the Column Cap.

Position the Focus Assembly as required and secure it.

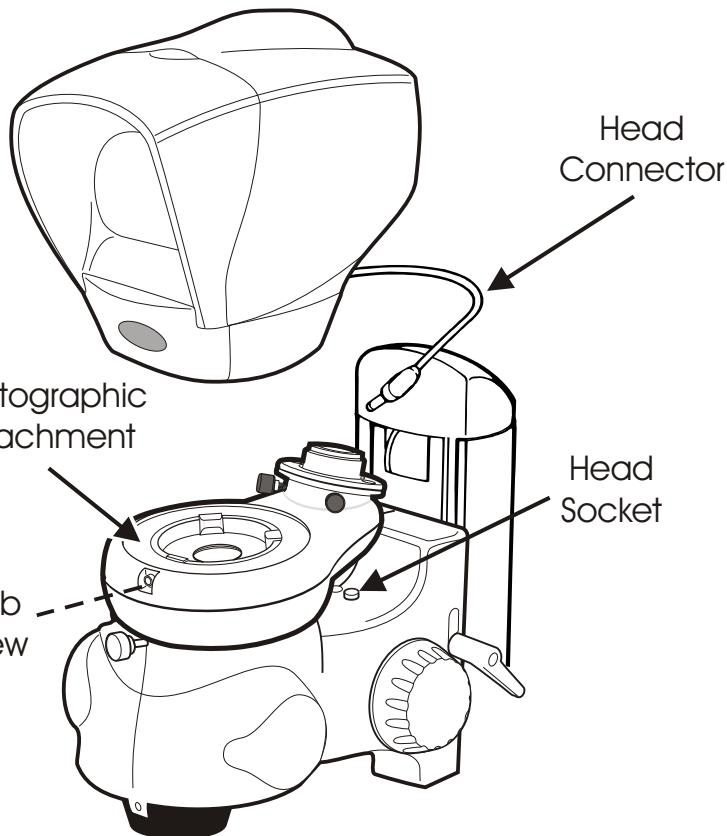
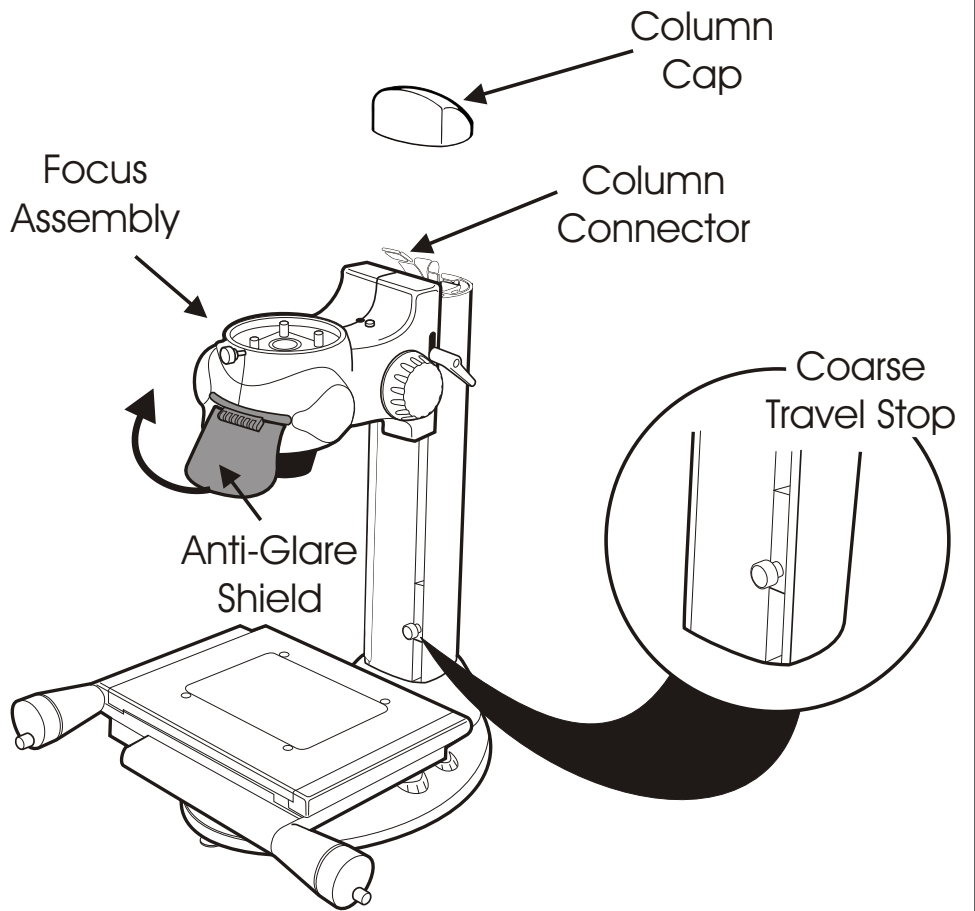

ATTACHING HEAD

Place the Head on to the Focus Assembly. Adjust Head until the crossline is parallel with the stage movement in the X axis. Tighten the securing screw. Insert the Head Connector in the Head Socket.

EPI ATTACHMENT

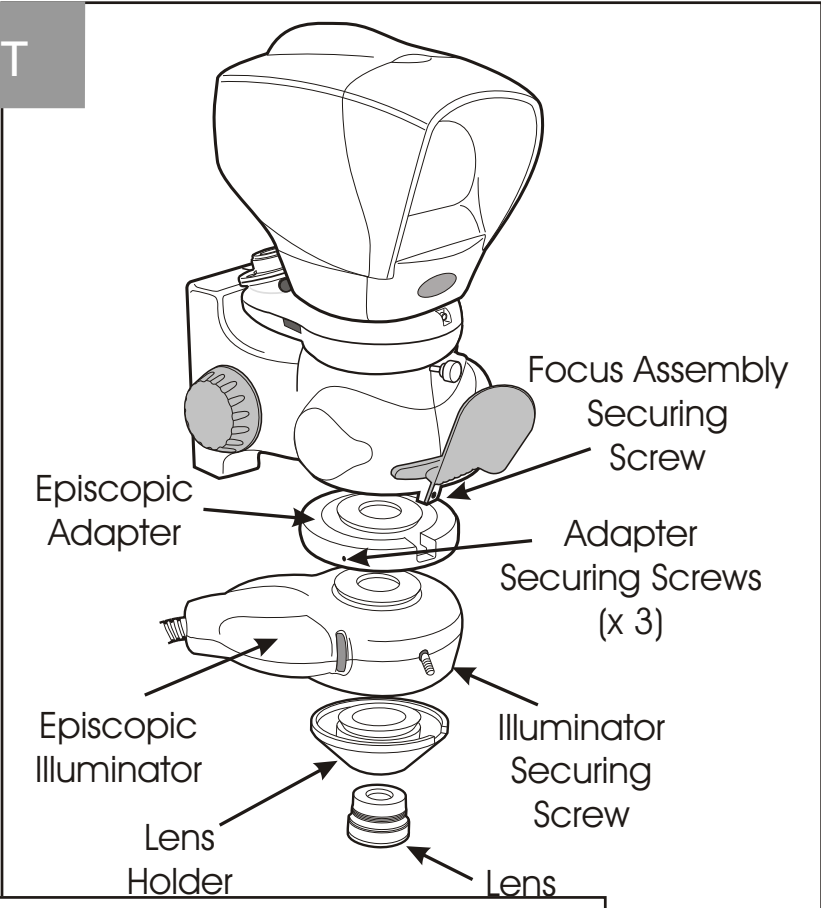

RINGLIGHT & SPOTLIGHT ATTACHMENT (WITH EPI)

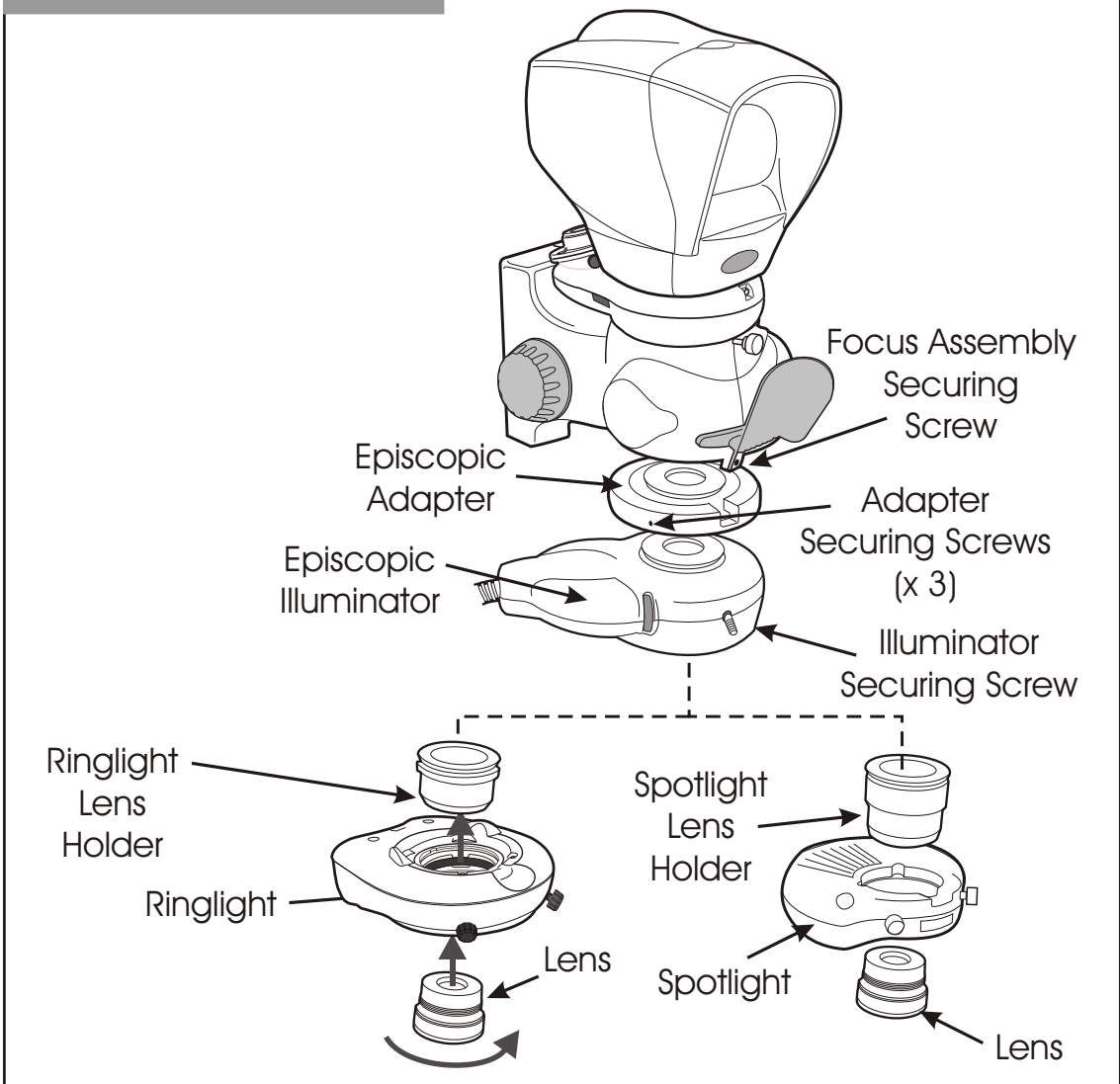

OBJECTIVE LENS

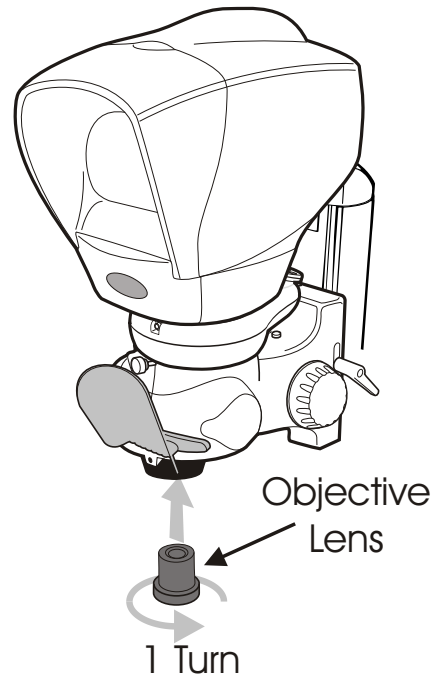

ATTACHING LED RINGLIGHT

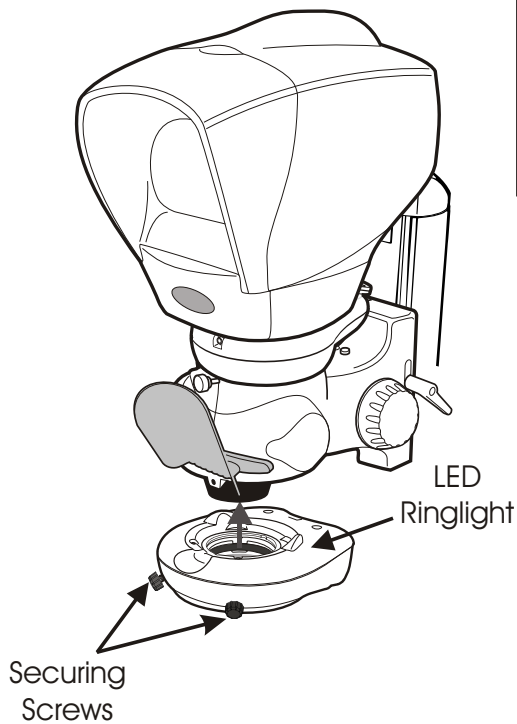

Place the ringlight into position and tighten the securing screws. Attach the cable to the control box (see page 4).

ATTACHING SPOT ILLUMINATOR

Place the Spot Illuminator into position and tighten the securing screws. Insert the illuminator's connector into the socket underneath the Focus Assembly.

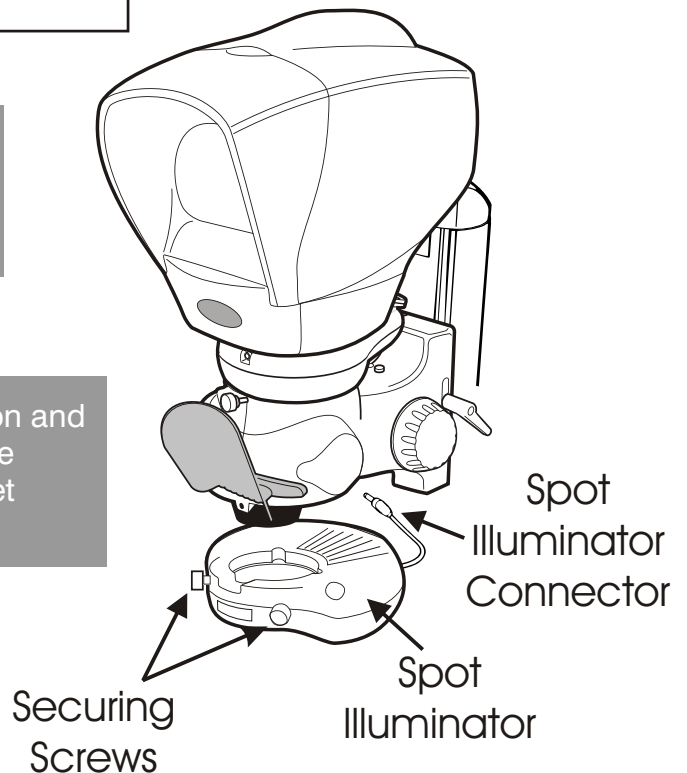

PHOTOGRAPHIC ATTACHMENTS

Attach adapter to camera and tighten 3 x grub screws if not already fitted.

Locate camera and adapter to locking plate (the locking plate must not be overtight, but enough to hold).

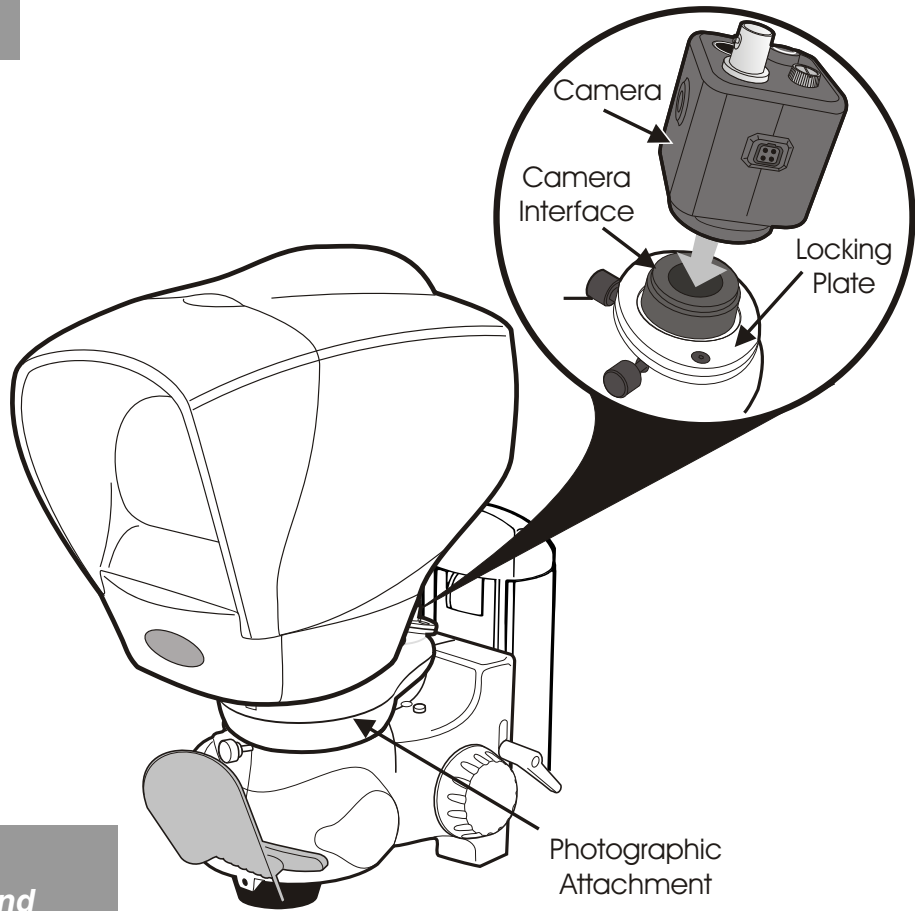

NOTE:
Adapters for 35mm and CCTV/Digital cameras are different.

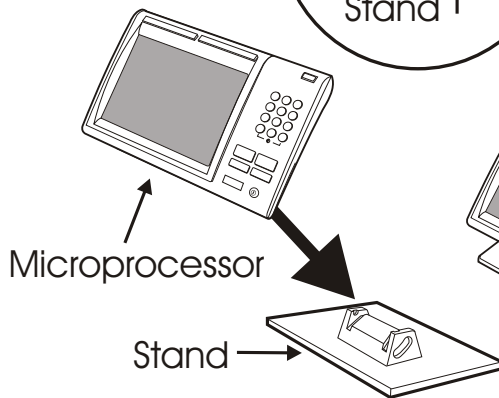
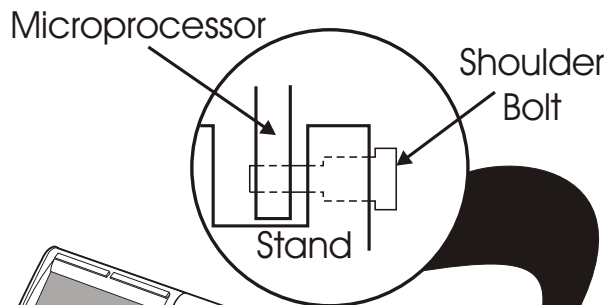

NOTE:
Do Not Over-tighten

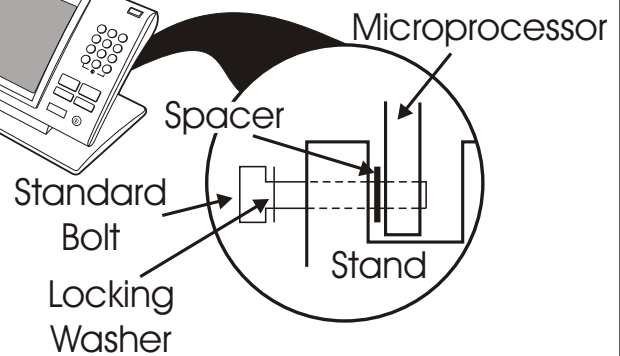

MICROPROCESSOR ASSEMBLY

SYSTEM CABLE CONNECTION

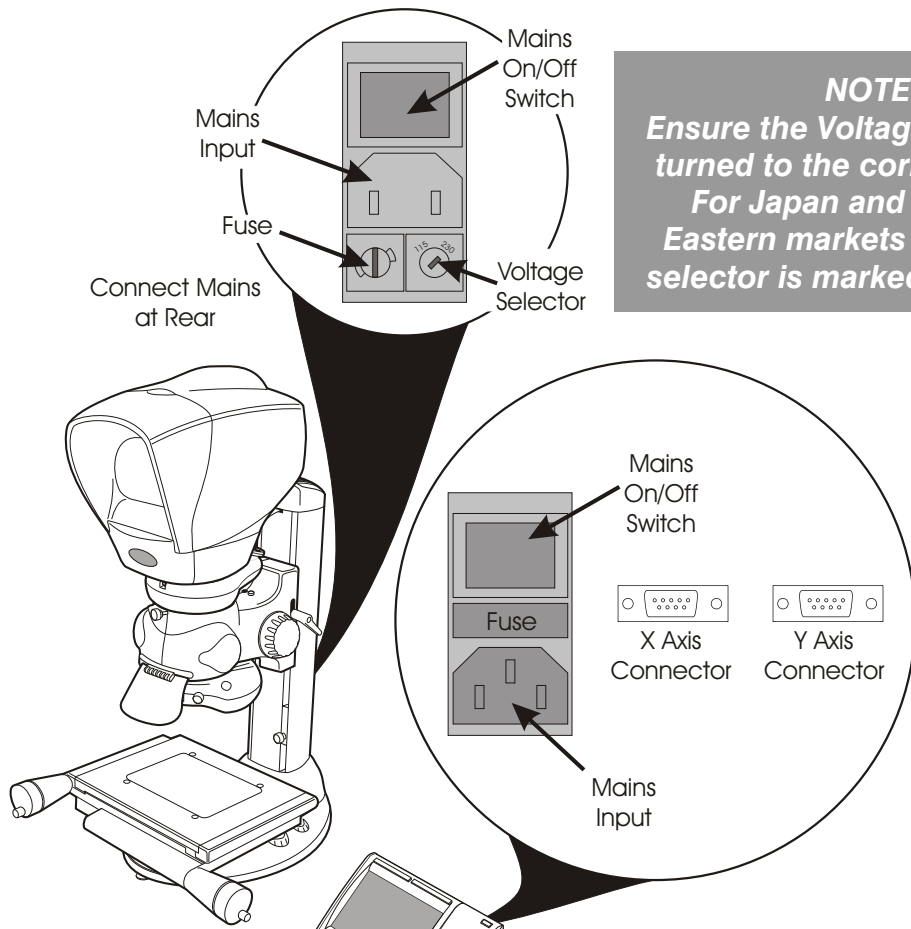

NOTE:
Ensure the Voltage Selector is turned to the correct setting. For Japan and some Far Eastern markets the voltage selector is marked 100 - 110V.

Connect the X and Y Axis leads from the Stage to the rear of the Microprocessor as shown.

Connect the mains leads to the mains connectors on the rear of the units.

Camera Setup

Connect camera to Quadra-Chek system using S-Video cable.

Attach power lead to camera and switch on.

Match orientation of video image with that of the image visible in the head

Bring the target/slip into focus within the head, as centrally aligned to crosshair as possible.

Match the view on the monitor with that in the head - move the camera by using the thumbscrews.

Once aligned, tighten the hexagonal headed screws on the locking plate to hold camera in position.

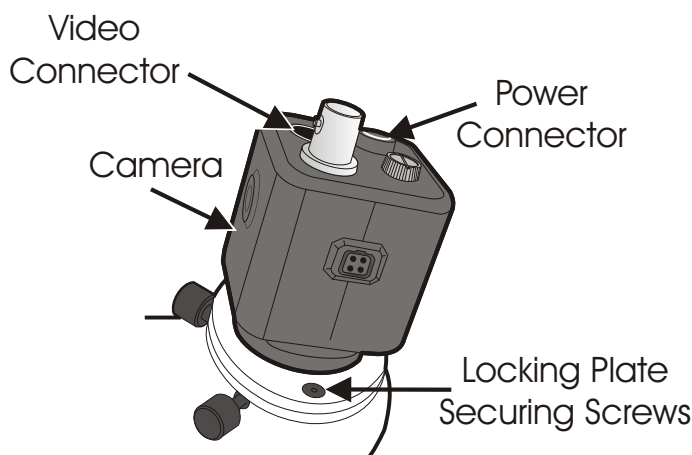

MAIN SYSTEM CONTROLS

Switch the Peregrine On and check the red LED at the centre of the Vision logo on the front of the Head is illuminated.

Adjust the Height Adjustment Control until you can focus on the Stage Glass then adjust the Focus Control for optimum focus.

Move the Travel Stop up to the base of the Focus assembly and lock it in place.

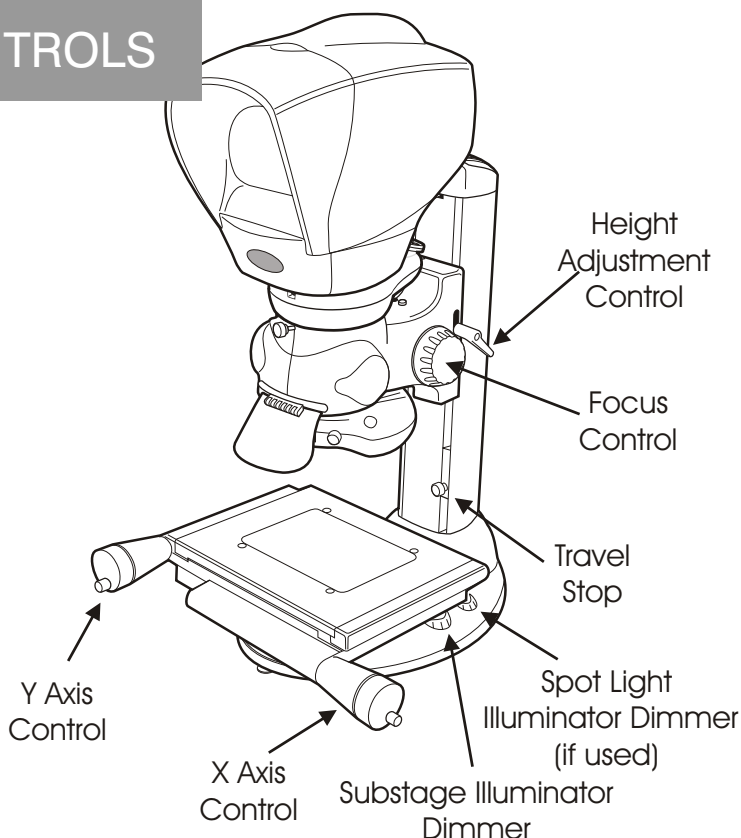

STAGE GLASS LEVELLING

Use the X and Y Axis controls to bring the rear right-hand corner of the Stage Glass (Fixed Corner) into view.

Use the Fine Focus Control to bring the glass surface into sharp focus.

Use the axis controls to bring the front right-hand corner into view. Use the relevant adjustable glass support to bring the surface of the glass into sharp focus.

Repeat for the remaining 2 corners.

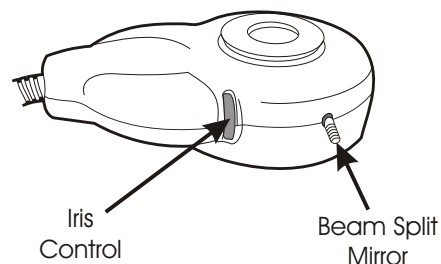
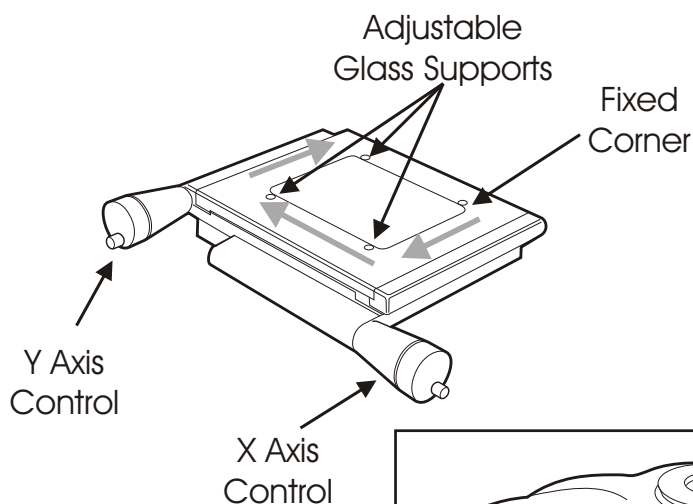

Object Lens
Iris Control

EPI/LENS CONTROLS

NOTE:

The crosshair graticules are factory set and should not need routine adjustment.

Depress the securing clip at the base of the front cover and lift the cover off.

NOTE:

The left-hand graticule is presented to the right-hand eye.

To focus and centralize each graticule, loosen the appropriate retaining knob and move the graticule up or down for focus. Re-tighten the retaining knob.

To adjust the graticules, place a known 90° gauge (slip gauge or crossline) on the Stage and focus the image. Closing one eye, locate the crossline on the corner of the gauge (see inset right) by unlocking and adjusting the grubscrews. Once the image is located, lock the grubscrews with the locking nuts.

Repeat this procedure with the other eye. Make the adjustment so that the Graticules overlay each other.

NOTE:

If the image is uncomfortable to the eyes, repeat the procedure above.

With the unit on, cover one spotlight and adjust the other for maximum light on the subject.

Repeat the procedure for the other spotlight.

GRATICULE ADJUSTMENT

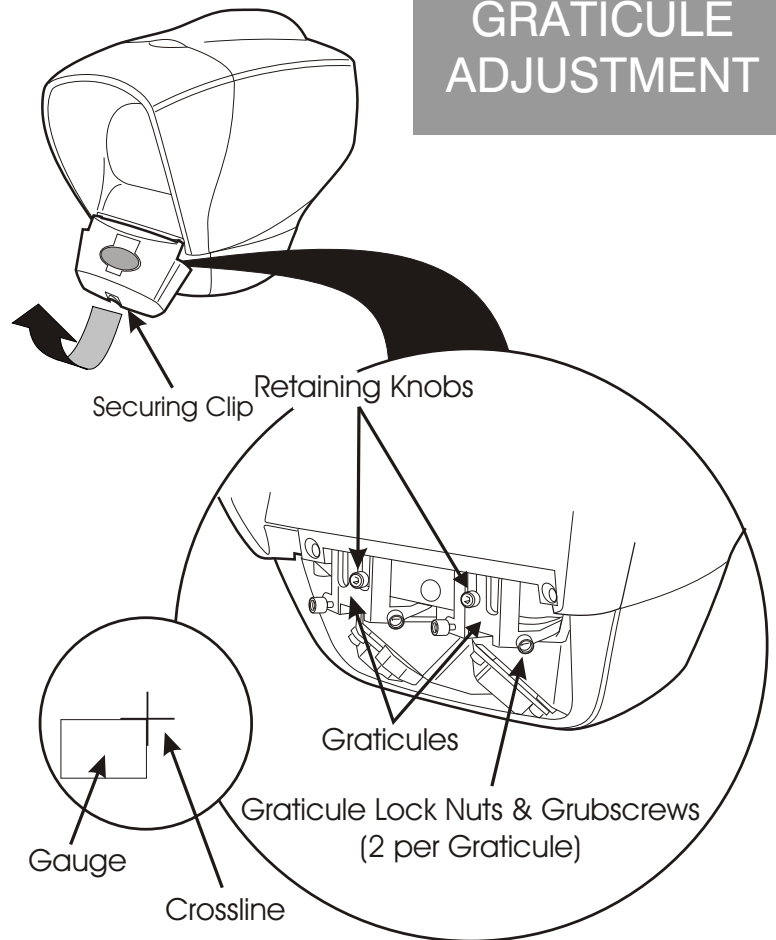



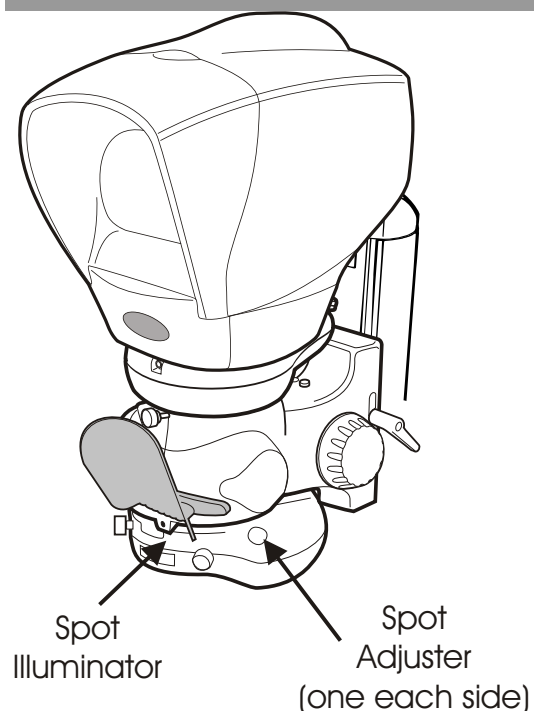

SPOT ADJUSTMENT



Head and LED illuminator control box

Icons

The icons on the front panel of the control box symbolise the following:

-  On/Off switch
-  Power on indicator
-  Illuminator intensity control
-  Ringlight connection point
-  Refer to manual

HEAD Power for viewing unit (boom mount only)

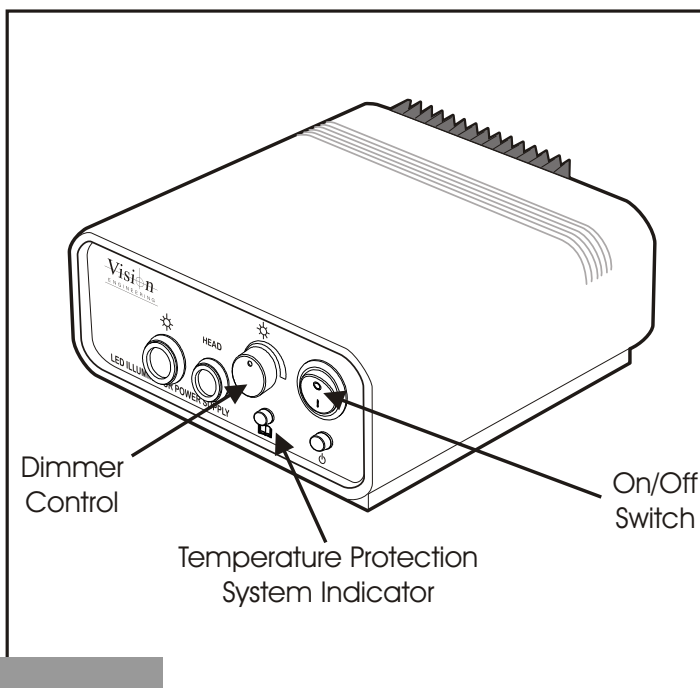

Controls

The LED ringlight, which can be used with substage illumination, provides above stage illumination and is used for illuminating surface features, etc.

Switch the unit on and adjust intensity by rotating the dimmer control.

The LED illuminator is provided with a temperature protection system to ensure long term LED performance is not compromised by overheating.

If the temperature protection indicator illuminates, the power to the LED's will gradually reduce until the temperature stabilises. If the indicator remains illuminated, remove the illuminator and ensure neither the air inlet around the objective, nor the fan outlet are obstructed.

LED illuminator specification

The LED illuminator unit has an integral power supply with the following specification:

Input voltage: 110 to 240v ~ 50/60Hz 0.9A max

Fuse rating: 110v 1.0A anti-surge
230v 0.5A anti-surge

The fuse is located in the IEC mains connector on the rear of the control box.

To achieve the optimum results from your Peregrine Measuring System the illumination and optics need to be adjusted to provide the best possible image to the operator. Certain lighting options are better for some applications than others.

Illumination and focus should be adjusted until the image is clear and bright, with good contrast. Maximum contrast gives the best image resolution and allows for the highest level of accuracy and repeatability.

Contact your nearest Vision Engineering branch or distributor if you require further advice.

Objective Lens

Iris Control

Each objective lens has an adjustable iris which restricts the aperture of the lens. By rotating the control ring on the bottom of the objective lens, the iris opens and closes. Adjusting the objective lens aperture changes the amount of light passing back through the lens. This has the effect of slightly increasing or decreasing the depth of field. This feature is useful for subjects where greater surface definition is required.

Magnification Table

Part No.	Objective Magnification	Working Distance	Field of View
K-007	1x	81mm	14.2mm
K-008	2x	81mm	7.1mm
K-009	5x	61mm	2.84mm

Illumination Options

Spotlight

- For the illumination of relatively reflective surfaces.
- Used with lower magnification objective lenses.
- Can be used with substage and episcopic (Epi) illumination.

With the unit on, cover one spotlight and adjust the other for maximum light on the subject. Repeat the procedure for the other spotlight.

The two spots should be focussed on the subject being measured to maximise image contrast. Light intensity can be adjusted by rotating the thumbwheel on the base of the Peregrine stand.

Ringlight

- To illuminate optically difficult surfaces/surface features.
- For use with higher magnification objective lenses.
- Gives a shadow free image.
- Can be used with Episcopic and Substage illumination.
- Adjust light intensity by rotating dial control on LED control box.

Episcopic

- Through the lens illumination for measuring deep surface features, holes and blind bores.
- The light follows the optical path through the objective lens.
- Adjust surface lighting to suit the component by using the lens aperture adjuster and the beam split mirror.
- Adjust light intensity by rotating the dial control on the light power supply unit.
- Adjust depth of field of objective lens with iris control thumbwheel (a smaller iris increases the depth of field).
- Change image contrast by fully engaging the beam split mirror control lever.

Substage

- Understage illumination used only for the accurate measurement of through holes, profiles and edge features for example.
- Adjust intensity by rotating thumbwheel on Peregrine base.
- Can be used with spotlight, ringlight and Epi illumination systems.

Substage Aperture Stops

- Optional accessory for the substage illumination.
- Focus light over a smaller area and primarily used for focussing light on the edge of round components when looking over the radius.
- Component edge can be clearly defined using the aperture stop.
- Available aperture stops - K-024 for x1 objective lens, K-025 for x2 objective lens and K-026 for x5 objective lens.
- Aperture stops screw into substage condenser lens and can be used with any filters.

Taking a Measurement

Optical

Select crosshair tool from the video tools menu and then 'DRO' to enable optical measurement.

Select the correct lens for the component being measured based on size of component and field of view (see magnification table). Focus the head on the feature to be measured by adjusting the head and focus assembly on the stand, firstly with the height adjustment control. Do this by undoing the locking lever on the focus assembly side and moving the whole assembly up or down the stand dovetail. Fine focus is achieved by rotating the focus control wheel on either side of the focus assembly.

A measurement is made by moving the subject on the stage under the cross-line graticule in the viewing head field of view. Distances moved and features created are accurately measured by glass scale encoders moving in X and Y at a resolution of $1\mu\text{m}$. These X and Y measurements are then translated into useable data by the QC-300 microprocessor.

- Lines can be measured by aligning the cross-line at a minimum of two points.
- Circles can be measured by aligning the cross-hair at a minimum of three points on the circle's circumference.
- A point is located by aligning the cross-hair on a single point.
- Further details on making measurements can be found in the QC-300 microprocessor user guide.

The accuracy of stage movement is achieved by the application of Non Linear Error Correction (NLEC) which compensates for any mechanical stage errors across the whole useable stage area. A unique NLEC calibration data file is stored in the QC-300 relating to the stage being used.

Video

Select 'Video' to enable video measurement.

Select the correct lens for the component being measured based on size of component and field of view (see magnification table on page). Focus the head on the feature to be measured by adjusting the head and focus assembly on the stand, firstly with the height adjustment control. Do this by undoing the locking lever on the side of the focus assembly and moving the whole assembly up or down the stand dovetail. Fine focus is achieved by rotating the focus control wheel on either side of the focus assembly (see page 10).

A measurement is made by placing the subject on the stage, then moving the stage until the required edge of the feature is within the video tool or the crosshair is aligned (see QC-300 User Guide for further details).

Select the appropriate video tool

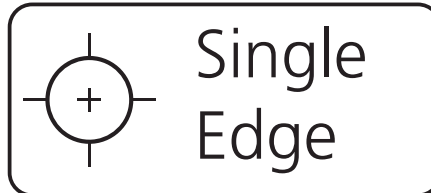

Further details on taking measurements can be found in the QC-300 microprocessor user guide.

Good Working Practices

When taking points on features the point should always be approached in the same fashion e.g. always work towards a point in the X axis first, moving from left to right. Next move towards a point in the Y axis, moving from top to bottom. This procedure will increase repeatability.

If looking to measure the form of a feature, it is best to take at least eight points to achieve the most repeatable result.

To achieve the very best from your Peregrine non-contact measuring system, you should carry out regular, routine maintenance as well as undertaking a schedule of servicing and calibration (see service & calibration record page)

Routine Maintenance (see pages 17, 18)

- The viewing screen should be periodically cleaned, using a non-abrasive optical cloth
- The outside of the instrument should be wiped down to remove any dirt and dust
- Illuminator air vents should be inspected and kept clear of any dust / debris
- The instrument and accessories should be checked for loose or damaged components.

Consumable & Replacement Parts:

Item	Specification	Part Number
Substage & spotlight bulbs	20W, 12V x4	C-101
Stage glass	150mm x 100mm	K-018
Anti-glare shield	Hinged glare shield	C-126
Substage Fuse	800mA quick blow fuse	FUS-0255

Environmental Considerations

Peregrine is an accurate, industrial gauging instrument. To achieve the optimum accuracy and repeatability, the following considerations should be taken into account:

- Position the Peregrine on a firm, rigid table
- Avoid locating the instrument near to any source of vibration
- Ensure Illuminator power supplies have sufficient ventilation
- Do not position the instrument close to a radiator or similar heating system
- Do not position the instrument in direct sunlight, or where bright reflections will prevent a comfortable viewing position.

Clean the viewing screen periodically with optical cloth.

**GENERAL
MAINTENANCE
POINTS**

If, after cleaning the viewing lens, the picture quality is below standard, remove and clean the graticules.

If the graticules require adjustment after they have been cleaned, see page 11.

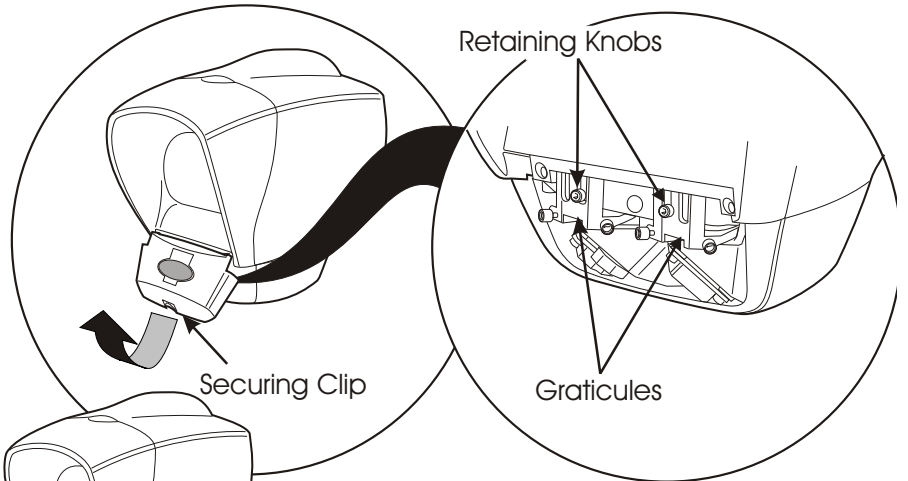

Viewing Lens

Changing the Sub-Stage Fuse:

Disconnect the unit from the mains supply.

Remove the 4 rubber feet from the base (push fit).

Remove the 5 base securing screws.

Replace the fuse with an 800mA quick blow type.

NOTE:
When the base is replaced, ensure the heat slots line up with the heatsink and substage bulb.

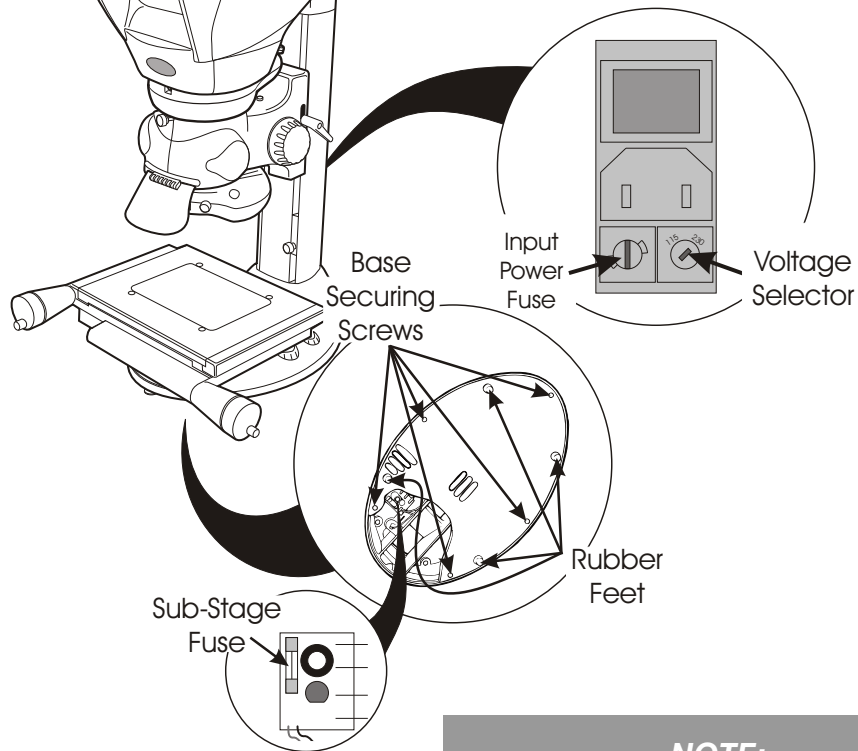

NOTE:
Ensure the Voltage Selector is turned to the correct setting. For Japan and some Far Eastern markets the voltage selector is marked 100 - 110V.

ILLUMINATOR LAMP CHANGING

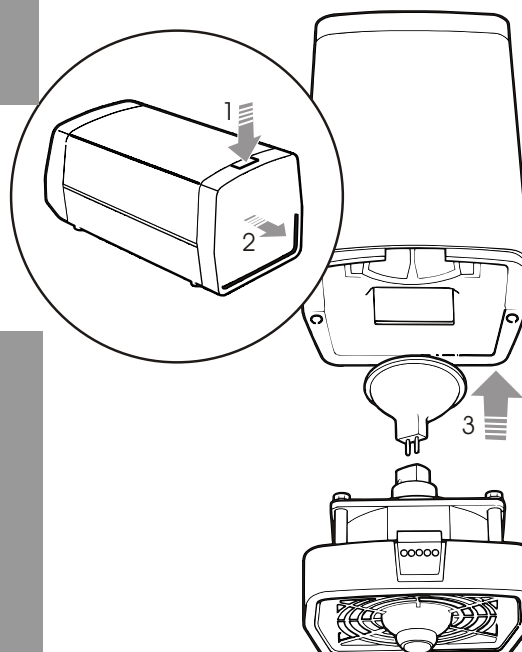

NOTE:
ENSURE THE ILLUMINATOR IS NOT HOT.

Press down the bulb/fan assembly release button (see 1 above).

Lift out the bulb/fan assembly (see 2 above).

Disconnect the lamp as shown in 3 above.

When relocating a lamp, ensure it is fully pushed into the lamp holder.

SUB-STAGE LAMP CHANGING

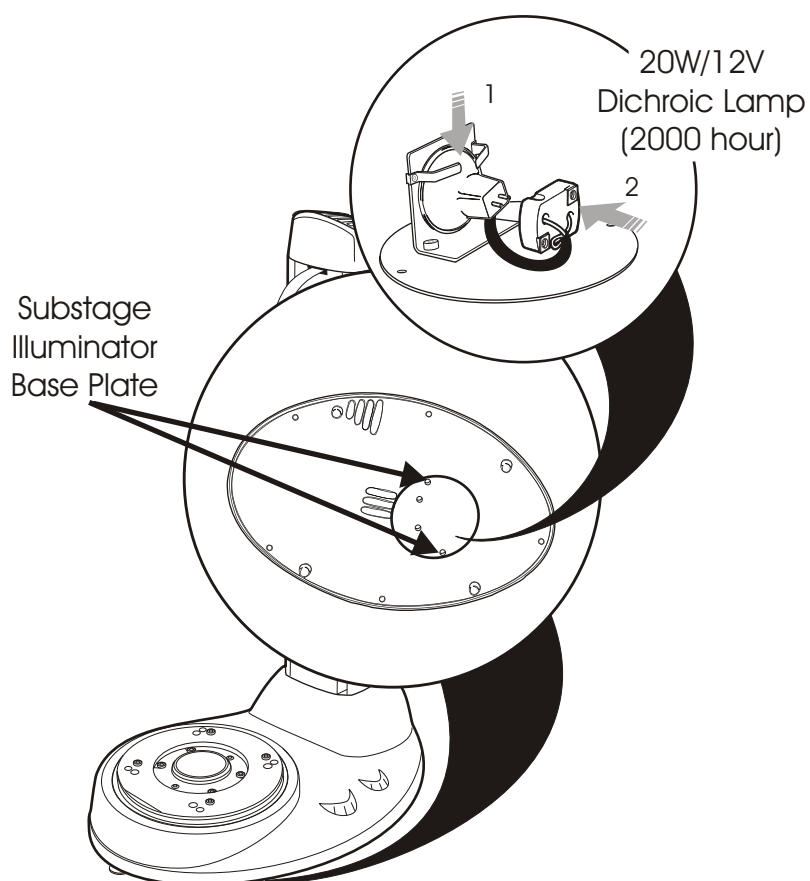

Disconnect the unit from the mains supply.

Carefully turn the stand on its side.

Remove the two outside bolts from the Substage Illuminator base plate and remove it, complete with Substage Illuminator.

Disconnect and remove the sub-stage illuminator bulb. Fit the new bulb (see 1 and 2 left) and replace the illuminator.

FAMILY TREE

Peregrine 2 Axis Non-contact Measurement System

FOR INSPECTION & GENERAL MICROSCOPE APPLICATIONS (last update Feb 08)

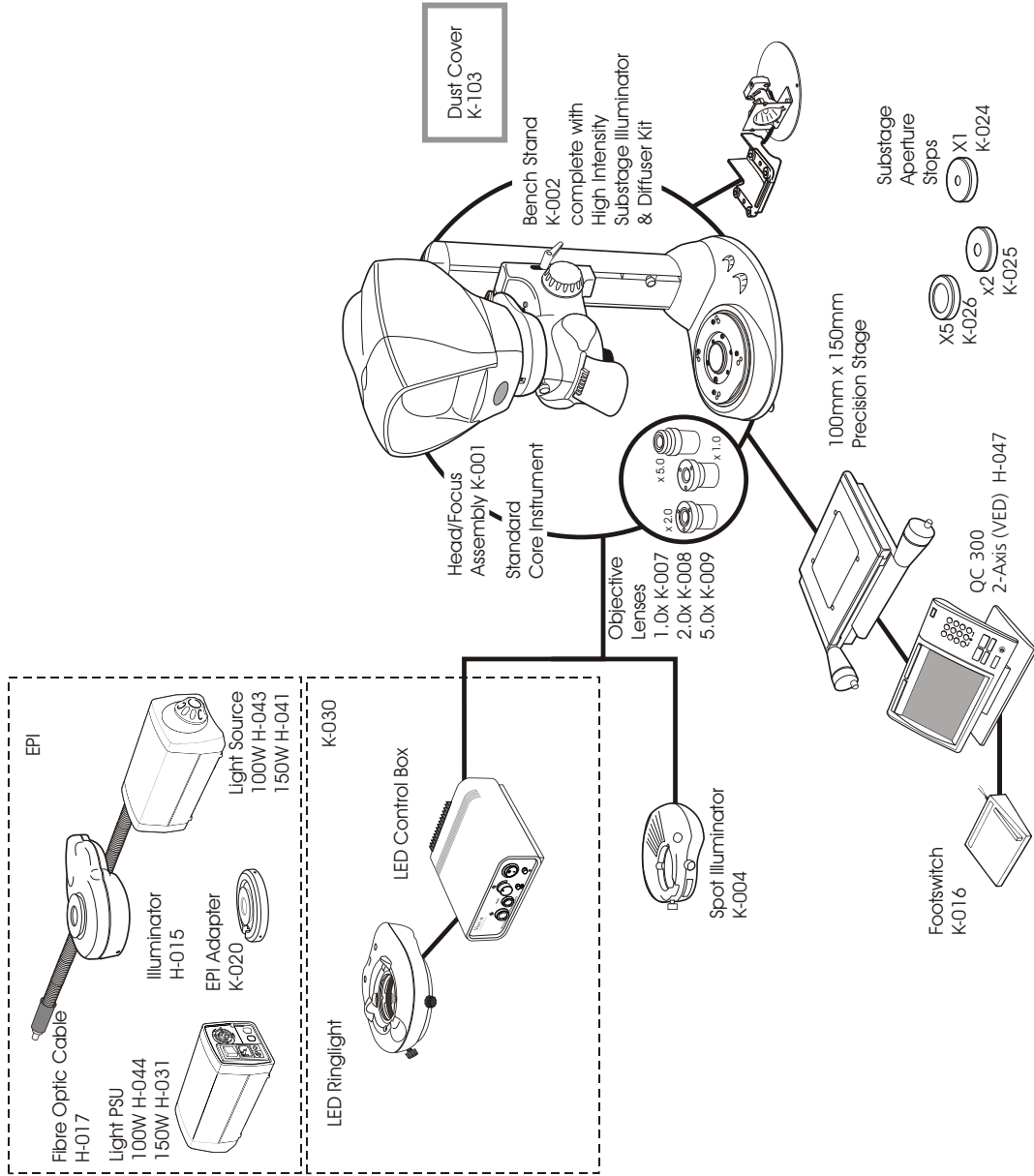

A wide range of optional accessories can be used with the Peregrine measuring system, further expanding on system capability. For further details, either visit the website or contact your local Vision Engineering branch / distributor.

Ringlight

An LED ringlight unit, providing shadow free illumination. The eight points of light ensure uniform illumination across the subject.

Episcopic Illumination

Light is projected through the objective lens, following the same path as the image. This is ideal for applications where the subject is flat and reflective or where light needs to be projected into a blind hole.

Camera Arm

The camera arm is fitted between the optical head and the body of the Peregrine instrument. Video or still image can be captured using digital or CCTV video cameras with a 'C' mount threaded adaptor.

Lens Options

In addition to the standard x2 objective lens, x1 and x5 options are available.

Anti-glare Hood

Where the Peregrine is used in conditions with high levels of ambient light, an anti-glare hood can be fitted around the viewing head. This hood reduces the level of glare from ambient light that an operator may notice in certain viewing conditions.

Peregrine Foot Switch





For entry of multiple data points, the foot switch connects directly into the QC-300 microprocessor.

Parts List

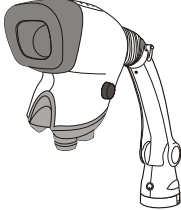

Item	Specification	Part Number
LED Ringlight, LED Control Box	8 Point LED Ringlight	K-030
Episcopic Illuminator	Fibreoptic episcopic lamp	H-015
Episcopic Ring	Episcopic Mounting Adaptor Ring	K-020
Fibre Optic	Fibre Optic Cable	H-017
Camera Arm	Camera arm & Digital camera adaptor	K-010 & K-031
Lens options	X1 & X5 Objectives	K-007, K-009
Anti-glare Hood	Shield to reduce ambient light	L-010
Peregrine Foot Switch	Foot switch for data entry	K-016
Power Supply	Power Supply 150W	H-031
Light Source	Light Source 150W	H-041
Power Supply	Power Supply 100W	H-044
Light Source	Light Source 100W	H-043

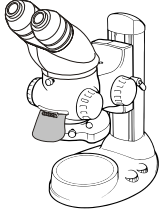
Vision Engineering manufactures a wide range of stereo inspection and non-contact measuring systems. Here is a summary of the products utilising Vision's technology that are available to you.

Stereo Inspection Systems

Product	Picture	Features	Description
New Mantis		<ul style="list-style-type: none"> • X4 - X20 Magnification • Shadow-free LED cold illumination, both surface and substage • Long working distances, large depth of field 	The New Mantis family is a unique range of optical systems without eyepieces, for intricate tasks requiring superb quality viewing over long periods of time. Available with universal variable boom mount or as a rigid stand mounted option in the low investment Mantis Compact, high performance Mantis Elite and straight-through view Mantis Macro.
Alpha		<ul style="list-style-type: none"> • X2.1 – X160 magnification • 80mm – 2mm field of view • Camera option • Expanded pupil eyepieces 	Expanded pupil eyepiece stereo zoom microscope. Available in boom and rigid stand configuration with a wide range of optional accessories (e.g. lighting, cameras)
Beta		<ul style="list-style-type: none"> • X2.1 – X160 magnification • 77mm – 1.75mm field of view • Camera option • Conventional eyepieces 	Conventional eyepiece stereo zoom microscope. Available in boom and rigid stand configuration with a wide range of optional accessories (e.g. lighting, cameras)
Lynx		<ul style="list-style-type: none"> • X2.1 – X120 magnification • 77mm – 1.75mm field of view • Camera option • Eyepieceless viewing system 	Advanced eyepieceless stereo zoom microscope. Available in boom and rigid stand configuration with a wide range of optional accessories (e.g. lighting, cameras)

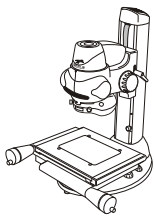
Non-Contact Measuring Systems

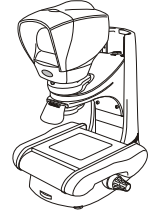
Product	Picture	Features	Description
Kestrel		<ul style="list-style-type: none"> • 150mm x 100mm stage • X10 – X50 mag options • QC200 Microprocessor • Eyepieceless viewing system 	Entry level, 2-axis measuring system. Ideal for shop floor gauging applications.
Merlin		<ul style="list-style-type: none"> • 150mm x 100mm stage • x10 - x50 mag options • QC-300 Microprocessor • Manual/Automatic Video Edge Detection 	2-axis video measuring system with touch screen video processor. Powerful yet simple to use, ideal for a wide range of gauging applications.
Hawk Manual		<ul style="list-style-type: none"> • 150mm x 150mm stage • X10 – X1000 mag options • 2 or 3 axis capability • Large stage option • Eyepieceless viewing system 	Advanced manual measuring system, offering increased accuracy and capacity.
Hawk Precision		<ul style="list-style-type: none"> • 200mm x 150mm stage • X10 – X1000 mag options • 2 or 3 axis capability • Eyepieceless viewing system 	High accuracy measuring system for 2 and 3 axis measurement. Operates with QC200 microprocessor or QC5000 PC software.
Hawk Automatic		<ul style="list-style-type: none"> • 200mm x 150mm stage • X10 – X100 mag options • Video Edge Detection • Motorised stage movement • 2 or 3 axis capability 	Automated measuring system combining optical viewing head with PC based Video Edge Detection. 2 and 3 axis motorised stage movement controlled by QC5000 PC software.

Peregrine Serial Number _____

Stage Serial Number _____

Service Type	Comments	Date of Service	Date of Next Service	Company	Signature

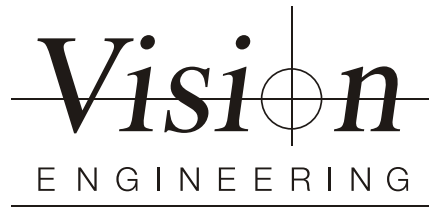

WARRANTY

This product is warranted to be free from defects in material and workmanship for a period of one year from the date of invoice to the original purchaser.

If during the warranty period the product is found to be defective, it will be repaired or replaced at facilities of Vision Engineering or elsewhere, all at the option of Vision Engineering. Shipment costs for warranty repairs, to and from Vision Engineering facilities will not, normally, be borne by Vision Engineering. However, Vision Engineering reserves the right to refund the purchase price if it is unable to provide replacement, and repair is not commercially practicable or cannot be timely made. Parts not of Vision Engineering manufacture carry only the warranty of their manufacturer. Expendable components such as fuses carry no warranty.

This warranty does not cover damage in transit, damage caused by misuse, neglect, or carelessness, or damage resulting from either improper servicing or modification by other than Vision Engineering approved service personnel. Further, this warranty does not cover any routine maintenance work on the product described in the user guide or any minor maintenance work which is reasonably expected to be performed by the purchaser.

No responsibility is assumed for unsatisfactory operating performance due to environmental conditions such as humidity, dust, corrosive chemicals, deposition of oil or other foreign matter, spillage, or other conditions beyond the control of Vision Engineering.

Except as stated herein, Vision Engineering makes no other warranties, expressed or implied by law, whether for resale, fitness for a particular purpose or otherwise. Further, Vision Engineering shall not under any circumstances be liable for incidental, consequential or other damages.

For more information...

Vision Engineering has a network of offices and technical distributors around the world. For more information, please contact your Vision Engineering branch, local authorised distributor, or visit our website.

Vision Engineering Ltd.
(Manufacturing)
Send Road, Send, Woking,
Surrey, GU23 7ER, England
Tel: +44 (0) 1483 248300
Fax: +44 (0) 1483 223297
Email: generalinfo@visioneng.com

Vision Engineering Inc.
(Manufacturing & Commercial)
570 Danbury Road, New Milford,
CT 06776 USA
Tel: +1 (860) 355 3776
Fax: +1 (860) 355 0712
Email: info@visioneng.com

Vision Engineering Ltd.
(Central Europe)
Anton-Pendele-Str. 3,
D-82275, Emmering, Germany
Tel: +49 (0) 8141 40167-0
Fax: +49 (0) 8141 40167-55
Email: info@visioneng.de

Vision Engineering Ltd.
(France)
1 Rue de Terre Neuve, ZA Courtaboeuf,
91967 Les Ulis Cedex, France
Tel: +33 (0) 164 46 90 82
Fax: +33 (0) 164 46 31 54
Email: info@visioneng.fr

Vision Engineering Ltd.
(Commercial)
Monument House, Monument Way West,
Woking, Surrey, GU21 5EN, England
Tel: +44 (0) 1483 248300
Fax: +44 (0) 1483 248301
Email: generalinfo@visioneng.com

Vision Engineering Inc.
(Commercial West Coast USA)
745 West Taft Avenue, Orange,
CA 92865 USA
Tel: +1 (714) 974 6966
Fax: +1 (714) 974 7266
Email: info@visioneng.com

Nippon Vision Engineering
(Japan)
272-2 Saedo-cho, Tsuduki-ku,
Yokohama-shi, 224-0054, Japan
Tel: +81 (0) 45 935 1117
Fax: +81 (0) 45 935 1177
Email: info@visioneng.jp

Vision Engineering Ltd Italia
(Italy)
Via Cesare Cantù, 9
20092 Cinisello Balsamo MI, Italy
Tel: +39 02 6129 3518
Fax: +39 02 6129 3526
Email: info@visioneng.it

Distributor

Vision Engineering Ltd
(China)
11J, International Ocean Building,
720 Pudong Avenue, Shanghai,
200120, P.R. China
Tel: +86 (0) 21 5036 7556
Fax: +86 (0) 21 5036 7559
Email: info@visioneng.com.cn

Vision Engineering
(India)
Tel: +91 (022) 2613 0699
Fax: +91 (022) 2610 3845
Email: info@visioneng.com.in

LIT 41131 R1.0/03/08

Visit our multi-lingual website:

www.visioneng.com